

14th Deep Sea Offshore Wind R&D Conference, EERA DeepWind'2017, 18-20 January 2017,
Trondheim, Norway

Fatigue behaviour of grouted connections at different ambient conditions and loading scenarios

Peter Schaumann^a, Alexander Raba^a, Anne Bechtel^b

^a*Institute for Steel Construction, Leibniz Universität Hannover, Appelstr. 9A, 30167 Hannover, Germany*

^b*wpd offshore solutions GmbH, Stephanitorsbollwerk 3, 28217 Bremen, Germany*

Abstract

Grouted connections are frequently used as structural detail of offshore wind turbines and platforms for the load transferring connection between piles and support structure. At latticed substructures this connection is commonly located at mudline. However, a potential influence of the surrounding water on the connection's fatigue behaviour was neglected in earlier tests and consequential design methods. Herein described experimental investigations at small and large-scale fatigue tests in submerged conditions showed a significant reduction of endurable load cycles. In addition, the water impact caused varied damage mechanism in the connection.

© 2017 The Authors. Published by Elsevier Ltd.

Peer-review under responsibility of SINTEF Energi AS.

Keywords: offshore wind energy; offshore platform; grouted connection; fatigue; water impact

1. Introduction

Lattice substructures of offshore wind turbines and platforms, like tripods or the jacket shown in Fig. 1, are connected to their foundation piles via grouted connections. The connection is located just above the seabed and hence constantly submerged. A watertight sealing against ingress of surrounding water is usually not applied.

The connection consists of a steel tube with smaller diameter (pile), which is plugged into a steel tube with larger diameter (sleeve). The resulting annulus between the steel tubes is filled with a high performance offshore specific grout material. For a defined interlocking between steel and grout, the steel surfaces are profiled with weld beads (shear keys).

The load bearing behaviour of the substructure splits, from wind and wave loads resulting, bending moments into axial force couples acting on the foundation piles (cf. Fig. 1). Therefore, the grouted connections in this type of substructure are predominantly axially loaded. Inside the connection areas of concentrated compressive stresses occur

between opposing shear keys (σ_{strut}). Analogous to truss structures these areas are called compression struts. Due to the strut inclination angle α also radial stresses arise and are borne by circumferential stresses ($\sigma_{\text{tangential}}$) inside the steel tubes.

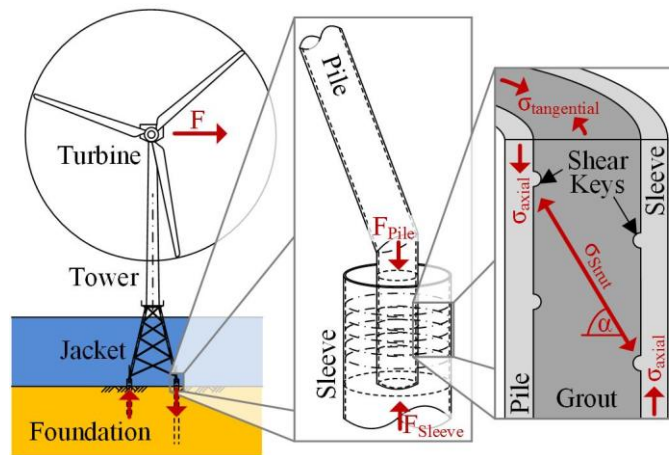

Fig. 1. Latticed substructure of an offshore wind turbine with structural details and load bearing behaviour of a grouted connection

Currently available design methods for grouted connections in latticed substructures from ISO 19902 [1] and DNVGL-ST-0126 [2] are based on load bearing and fatigue tests carried out in dry ambient conditions (AC) [3, 4]. However, tests on grout material specimens [5–7] as well as reinforced concrete specimens [8] showed a significantly reduced fatigue strength when carried out in wet AC.

As part of the research project ‘GROWup – Grouted Joints for Offshore Wind Energy Converters under reversed axial loadings and up scaled thicknesses’ a test setup to investigate the influence of water on the fatigue behaviour of grouted connections was developed. In the following the test setup and the achieved results regarding the influence of water will be presented.

2. Small-scale tests

2.1. Test setup

To simulate a realistic stress state inside the grout material, the small-scale specimen shown in Fig. 2 was developed [9]. Therefore, relatively compact steel tubes were chosen to prevent a failure of the steel tubes due to buckling or yielding. Rectangular shear keys were machined out of the steel surfaces. As filling material two commercial grout materials with a relatively low (Mat. 1, $f_{\text{cu}} = 90 \text{ N/mm}^2$) and a high strength (Mat. 2, $f_{\text{cu}} = 140 \text{ N/mm}^2$) were used.

The specimens were tested inside the water basin shown in Fig. 2. By the hydraulic cylinder pure axial compressive loads were applied. During the tests the applied load F , the relative displacement u of the load application plate and the number of applied load cycles N were measured.

After production of the specimens and 28 days of grout material curing the load bearing capacity F_{ULS} of three specimens was determined in a quasi-static test. Afterwards the mean value of F_{ULS} was used as load reference value for the subsequent fatigue tests. The maximum load level F_{max} as well as the loading frequency f were kept constant in the fatigue tests. The loading ratio was chosen to be $R = 20$ due to control system reasons. Real grouted connections are usually loaded with a loading frequency in the range of $f = 0.3 \text{ Hz}$. To allow a transferability of the fatigue test results obtained with a loading frequency of $f = 5.0 \text{ Hz}$, additional fatigue tests focusing on different loading frequencies were carried out in wet AC. Both dry and wet AC were investigated using tap water.

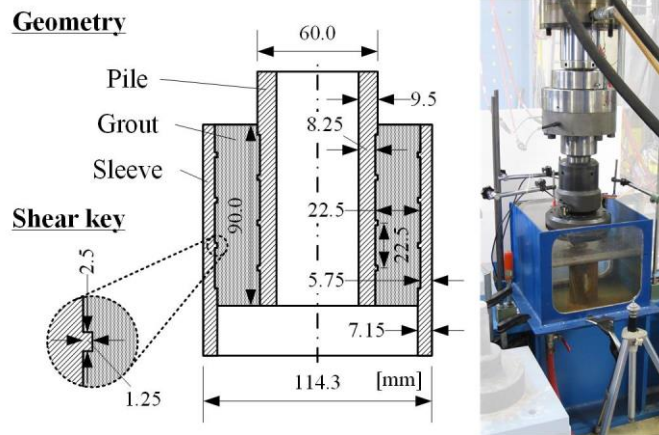

Fig. 2. Geometry of the small-scale specimen (left) and specimen in the test rig (right)

2.2. Results

In total 6 tests in dry as well as 26 tests in wet AC were carried out and evaluated. Accompanying material investigations [10] showed significant differences between the strength parameters given by the manufacturers and the actual values. The actual strength difference between the two materials was not statistically significant, hence it was possible to neglect an influence of the different materials in the evaluation.

In Fig. 3 the obtained endurable load cycles N with their corresponding loading level S are depicted. Thereby S represents the ratio between the load bearing capacity F_{ULS} determined in quasi-static tests and the applied maximum compressive load F_{max} of the fatigue tests. In dry AC with a loading level of $S = 0.5$ and a loading frequency of $f = 5.0$ Hz all specimens reached the test termination criterion of $N = 2$ million load cycles. In wet AC and identical loading conditions the specimens failed at an average of $N = 50'000$ load cycles. Prior tests [11] had already shown no specimen degradation in dry AC at this loading level. This can be explained by the static load bearing behaviour of the specimen, which is almost linear elastically up to this loading level [12]. The differences between the results obtained in dry and wet AC lead to the conclusion, that in wet AC different damage mechanisms occur.

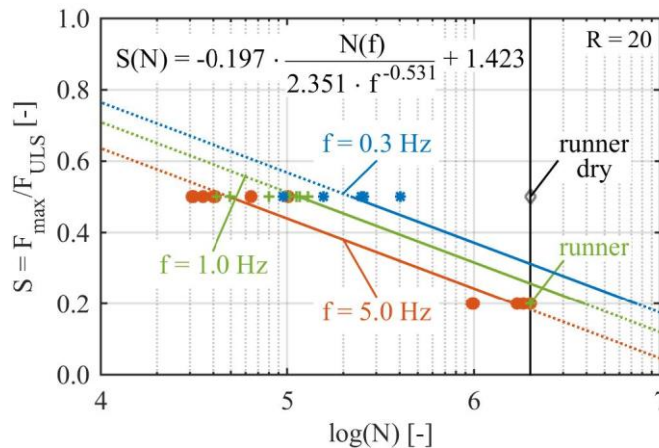

Fig. 3. Results of the small-scale fatigue tests and loading frequency dependent fatigue curve for wet ambient conditions

A reduction of the loading frequency leads to an increased number of endurable load cycles. Based on these results the frequency dependent fatigue curves for small-scale specimens shown in Fig. 3 were developed [13]. These findings are remarkable because prior investigations [6, 8] for specimens without confining steel tubes showed a contrary influence of the loading frequency. Ergo, the damage process is influenced by the interaction of steel and grout.

After completion of the fatigue tests the specimens were dismantled. In Fig. 4 one dismantled specimen tested in dry and one tested in wet AC are shown. While the specimen tested in dry AC shows no visible degradation in the grout segment, the other specimen shows compression strut failure in the lower grout segment, grout crushing in front of the shear keys of the pile and vertical cracks at the upper interface between grout and pile.

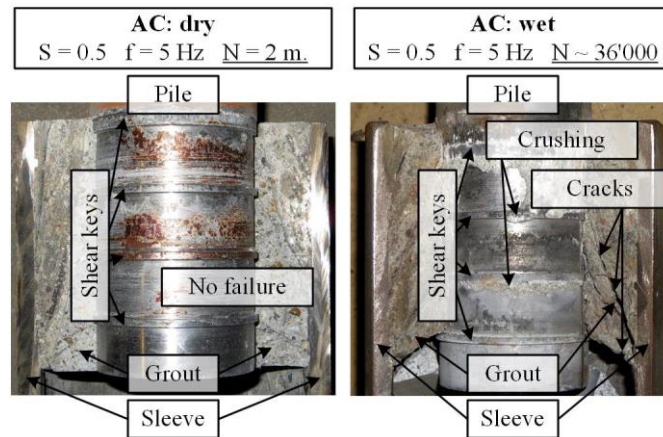

Fig. 4. Damage patterns of dismantled small-scale specimens

Conclusively, the damage behaviour can be described as follows. Until the fatigue tests start, the specimens are stored in a water basin. Therefore, at the beginning of the tests the grout segment is saturated with water. Applying the load, compresses water inside the specimen and presses water out of the interface between steel and grout. In dry AC this process is terminated after a few load cycles. In wet AC unloading the specimen leads to water being sucked into the interface again, a pumping process occurs. Additionally, pressurised water leads to local grout crushing at lower load levels than in dry AC. In combination with grout crushing caused by the local load application of the shear keys, crushed material particles accumulate in the interface. By the pumping process the grout particles are flushed out of the connection and an increase of relative displacement between pile and sleeve occurs. This damage behaviour leads to less endurable load cycles of grouted connections in wet AC.

3. Large-scale tests

3.1. Test setup

Coincidentally to the small-scale tests, large-scale fatigue tests with grouted connections for jackets were carried out to investigate the fatigue behaviour of large grout layers. At first, these tests were realised in dry AC. This allowed to investigate the applicability of state of the art design methods for this type of connection since these methods were derived from dry AC test results. Moreover, new design recommendations for this type of grouted connections were elaborated [14].

Subsequently, two large-scale fatigue tests were carried out in wet AC to investigate the influence of water on the fatigue behaviour of the connection. Using the grout material with higher strength (Mat. 2) the two geometries (G1 and G2) shown in Fig. 5 were investigated. The two geometries differ in the diameter of their pile and therefore in the thickness of their grout layer.

In contrast to the small-scale specimens with compact steel tubes, the large-scale specimens were developed as scaled versions of real structures (G1: ~ 1:2 jacket, G2: ~ 1:4 tripod) [14]. Similar to real structures, the shear keys were made of weld beads with the dimensions given in Fig. 5.

The grouting process was carried out under supervision of the material manufacturers and was accompanied by several material tests for both fresh and dried grout material. The grout annulus was dry during the grouting process to exclude not quantifiable influences of a submerged grouting process [15].

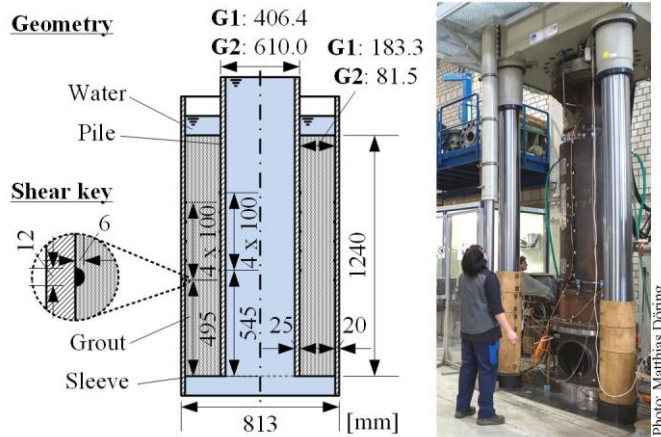

Fig. 5. Geometry of the large-scale specimen (left) and specimen in the test rig (right)

Before starting the tests, the specimens were filled with water to emulate the real AC of jackets. Similar to the small-scale tests, the applied load F , the relative displacement u between pile and sleeve and the number of applied load cycles N were measured.

Fig. 6 shows the load bearing capacities of the specimens according to current design methods [1, 2] as well as the planned load scenarios. The load scenarios were chosen to be incrementally increased each after 100'000 load cycles. Thereby, different load stages could be investigated and a fatigue induced failure was expected to be provoked [14]. The first three load stages (LS) were alternating loads ($R = -1$) and the following load stages were pure compressive loads ($R \rightarrow \infty$). The loading frequency was 1 Hz.

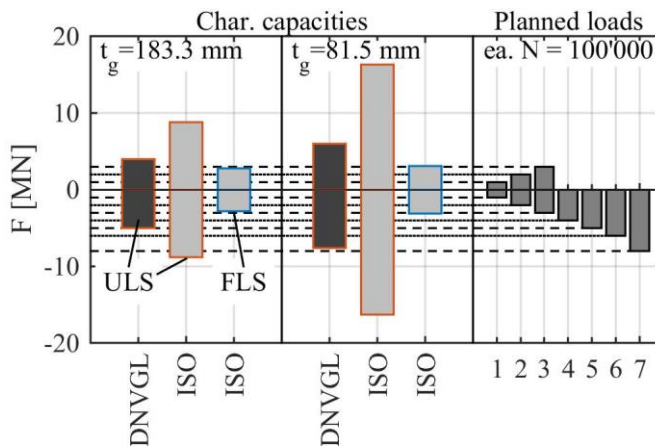

Fig. 6. Calculated characteristic capacities of the large-scale specimens and planned load scenario of the fatigue tests comprising 7 load stages

Table 1. Endurable load cycles in different ambient conditions

	t_g [mm]	Ambient condition	Failure
D1	183.3	dry	Load stage 7 (N~200)
W1		wet	Load stage 1 (N~95'000)
D2	81.5	dry	no failure
W2		wet	Load stage 2 (N~9'000)

3.2. Results

The large-scale fatigue tests also showed a significant reduction of endurable load cycles when carried out in wet AC. As stated in Table 1 the specimen D1 tested in dry AC failed in load stage 7 (LS), while specimen D2 showed no

reduced load bearing capacity after applying all LS [14]. In wet ambient conditions specimen W2 failed in LS2 within the first 9'000 load cycles and specimen W1 failed already in LS1.

As shown in Fig. 7 for specimen W1 a continuous increase of the displacement range $\Delta u(N_i) = u_{\max}(N_i) - u_{\min}(N_i)$ per load cycle N was measured. The hysteretic loop evolution depicted in Fig. 8 elucidates that the displacement increase is localised around the load's zero crossing. At the same time the specimen's stiffness remains constant, which can be derived from the inclination of the hysteretic loops. This behaviour implies a damage of the interface between steel and grout and will be called connection backlash in the further description. At the end of LS1 the displacement increase rises significantly and a second peak per half hysteretic loop evolves (cf. Fig. 7). From this point on the connection shows no further stable load bearing behaviour. Hence, the occurrence of a second peak was chosen as failure criterion to define the endurable load cycles given in Table 1.

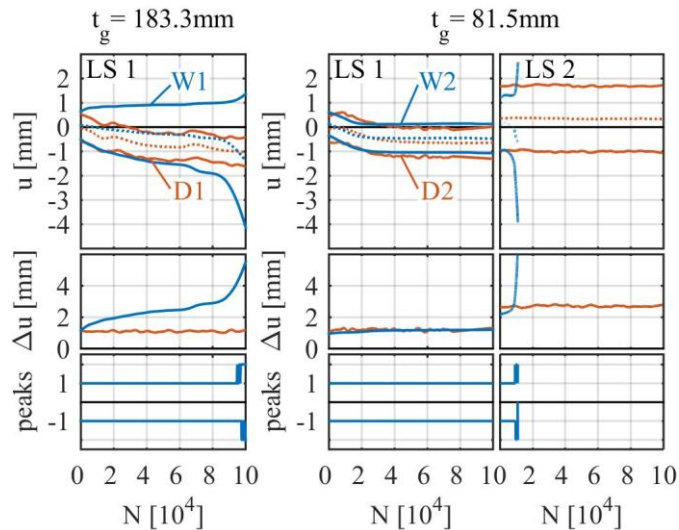

Fig. 7. Displacement behaviour of the specimens in different ambient conditions (D = dry, W = wet) in dependency of the number of load cycles

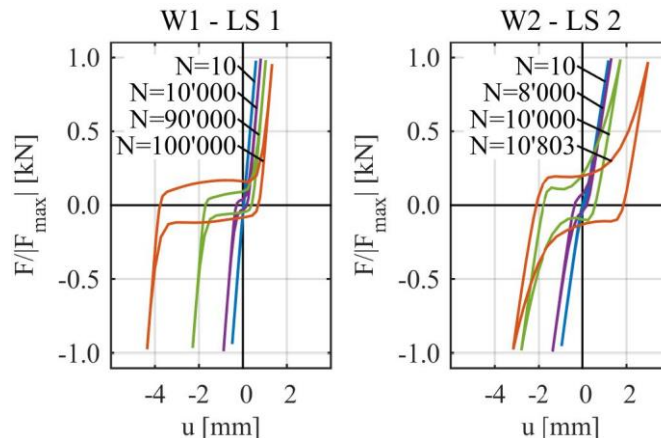

Fig. 8. Normalised hysteretic loop evolution for the load scenarios of specimen failure of the specimens tested in wet AC

After completion of the fatigue tests the large-scale specimens were dismantled and the damage mechanisms were analysed. The specimens tested in dry AC showed a severely damaged grout layer with loose grout particles and segments (cf. Fig. 9). Both specimens D1 and D2 had cracks along the compression strut axes. The compression strut cracks were caused by tensile as well as compressive loading of the different load stages. Consequently, in both geometries crossing compression strut cracks occurred. The damage patterns imply, that in dry AC compression strut failure is the dominating failure mechanism. Besides the diagonal cracks, especially in the geometry with large grout

layer thickness, radial cracks were visible even before the tests started. Both crack types led to a severely damaged grout layer for the specimen with large grout layer thickness D1. In front of the shear keys also grout crushing occurred and a grout wedge similar to the investigations by Krahl & Karsan [16] was visible. Even though, the grout material showed brittle cracking, the specimens' failure was characterised by a ductile behaviour. The number of endurable load cycles was higher than expected. More details can be found in [14].

For the specimens tested in wet AC W1 and W2 the damage pattern is localised to the interface between sleeve and grout. This is remarkable, since this interface is less stressed due to its larger surface area. Both of the previously described displacement increase can be traced back to the widened grout groove around the shear keys, depicted in Fig. 10. In specimen W2 compression strut failure in the lower grout segment was visible. This crack occurred slightly before the specimen failed in LS2.

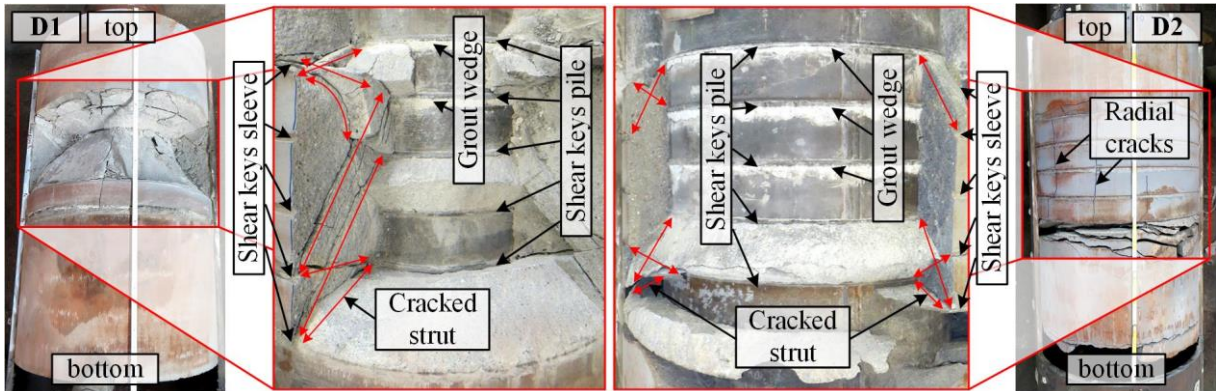

Fig. 9. Damage patterns of dismantled specimens D1 and D2

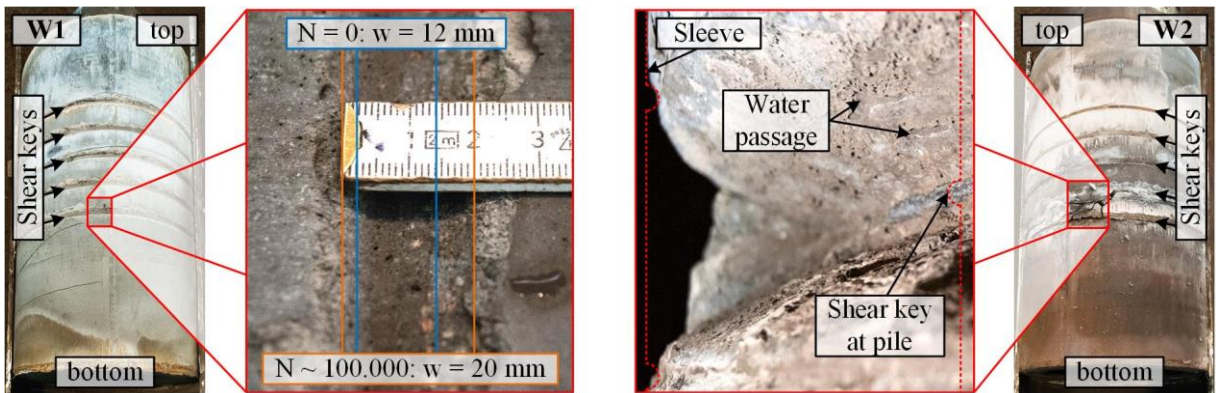

Fig. 10. Damage patterns of dismantled specimens W1 and W2

Based on the gathered data the damage mechanism of the specimens tested in wet AC can be described as follows. The local load application of the shear keys leads to grout crushing as also seen in the dry AC tests. The loosened grout particles are subsequently flushed out of the interface by the pumped water and the shear key groove widens. The connection backlash evolves and an impulsive load application after the load's zero crossing occurs. A speed up degradation results. The previously mentioned additional peak of the half hysteric loop correlates with the impulsive load. When considering the occurrence of the connection backlash after only a few load cycles, as shown in Fig. 8, an initial weakening of the interface between sleeve and grout must be assumed. This can be explained by autogenous shrinkage which leads to detached grout.

For the fatigue tests in dry AC the higher load bearing capacity of the geometry with the smaller grout layer thickness D2 can be explained by the more favourable compression strut inclination and the larger load transfer area between grout and pile. The damage patterns of the specimens W1 and W2 are localised to the larger load transfer

area between grout and sleeve. The thinner grout layer of specimen W2 leads to less radial shrinkage and therefore less initial weakening of the interface, which explains the higher load bearing capacity.

4. Conclusion and outlook

The presented small and large-scale fatigue tests with axially loaded grouted connections show a significant reduction of endurable load cycles when loaded in wet ambient conditions. Dominating parameters from the small-scale tests are the load level and the loading frequency. The large-scale tests confirmed the damage mechanisms observed in the small-scale tests. The damage pattern of the large-scale specimens implied a weakened interface between sleeve and grout due to autogenous shrinkage.

At the time being the presented large-scale fatigue tests are the only tests of this size investigating the influence of water on the fatigue behaviour and for an axially loaded grout segment. For a reliable consideration of the described phenomena in design methods further research is indispensable. Within the research project “GROWup“ four additional large-scale tests are planned.

Acknowledgement

The presented results are achieved within the research project ‘GROWup’ funded by the German Federal Ministry for Economic Affairs and Energy (BMWi, funding sign: 0325290). The research partners are Institute for Steel Construction and Institute of Building Materials Science, both at Leibniz Universität Hannover, Germany. The authors thank the BMWi for funding and all accompanying industry project partners (DNV GL, Senvion SE, Siemens Wind Power, Wilke & Schiele Consulting GmbH, Bilfinger Marine & Offshore Systems GmbH) for their support. In addition the authors thank the material manufacturers for their support. Concluding thanks goes to Prof. Lohaus and his team from the Institute for Building Materials Science for the excellent project collaboration.

References

- [1] EN ISO 19902. 2014. Petroleum and Natural Gas Industries – Fixed Steel Offshore Structures
- [2] DNVGL-ST-0126. 2016. Support structures for wind turbines
- [3] Billington, C. J.; Tebbit, I. E.: The Basis for New Design Formulae for Grouted Jacket to Pile Connections. In: Proceedings of the 12th Annual Offshore Technology Conference. Houston, Texas, USA, 1980, S. 449–458
- [4] Harwood, R. G.; Billington, C. J., et al.: Grouted Pile to Sleeves Connections: Design Provisions for the New ISO Standard for Offshore Structures, Volume III, Materials Engineering. In: Proceedings of the ASME 1996 15th ISOPE Conference. Florence, Italy, 1996
- [5] Nygaard, K.; Petkovic, G., et al.: High Strength Concrete, SP3 - Fatigue : Report 3.1: The Influence of Moisture Conditions on the Fatigue Strength of Concrete. Trondheim, Norway, 1992
- [6] Soerensen, E. V.: Fatigue Life of High Performance Grout in Dry and Wet Environment for Wing Turbine Grouted Connections. In: Proceedings of the European Windenergy Association Offshore Conference EWEA Offshore 2011. Amsterdam, Netherlands, 2011
- [7] Hümme, J.: Fatigue behaviour of high-strength grouting concrete tested under water. In: Proceedings of the fib Symposium on Concrete - Innovation and Design. May 18-20, Copenhagen, Sweden, 2015
- [8] Waagaard, K.: Experimental Investigation on the Fatigue Strength of Offshore Concrete Structures, Bd. 1. In: 9th Annual Energy Technology Conference. New Orleans, Louisiana, USA, 1986, S. 73
- [9] Schaumann, P.; Wilke, F.: Fatigue Assessment of Support Structures of Offshore Wind Energy Conversion Systems. In: SCHAUMANN, Peter; PEINKE, Joachim (Ed.) Annual Report 2005. Hannover, Germany, 2006, S. 36–39
- [10] Schaumann, P.; Raba, A.: Systematic Testing of the Fatigue Performance of Submerged Small-Scale Grouted Joints. In: Proceedings of the ASME 2015 34th OMAE Conference. May 31 - June 5, St. John's, Newfoundland, Canada, 2015
- [11] Schaumann, P.; Bechtel, A.; Lochte-Holtgreven, S.: Fatigue Performance of Grouted Joints for Offshore Wind Energy Converters in Deeper Waters. In: Proceedings of the 20th International Offshore and Polar Engineering Conference. Beijing, China, 2010, S. 672–679
- [12] Schaumann, P.; Raba, A.; Bechtel, A.: Effects of Attrition Due to Water in Cyclically Loaded Grouted Joints. In: Proceedings of the ASME 2014 33rd International Conference on Ocean, Offshore and Arctic Engineering. June 8-13, San Francisco, California, USA, 2014
- [13] Schaumann, P.; Raba, A.: Influence of the loading frequency on the fatigue performance of submerged small - scale grouted joints. In: Proceedings of the 12th German Wind Energy Conference DEWEK 2015. Bremen, Germany, 2015
- [14] Bechtel, A.: Fatigue Behaviour of Axially Loaded Grouted Connections in Jacket Structures. Hannover, Germany, Leibniz Universität Hannover, Institute for Steel Construction. Dissertation. 2016
- [15] Werner, M.; Lohaus, L.: Ausführungstechnische Einflüsse auf Aspekte der Tragsicherheit von Grouted Joints (Influences of in situ production of grouted joints on aspects of structural safety). In: Bautechnik 91 (2014), Nr. 8, S. 554–560
- [16] Krahl, N. W.; Karsan, D. I.: Axial Strength of Grouted Pile - to - Sleeve Connections. In: Journal of Structural Engineering 111 (1985), Nr. 4, S. 889 - 905